



## ANTENNA & CABLE MONITOR

SERIES ACM

OPERATION MANUAL

©COPYRIGHT 2016 BY BIRD TECHNOLOGIES INC.  
INSTRUCTION BOOK P/N 920-ACM REV. M  
THRULINE® IS A REGISTERED TRADEMARK OF  
BIRD ELECTRONIC CORPORATION

MICROSOFT® AND WINDOWS® ARE REGISTERED  
TRADEMARKS OF THE MICROSOFT CORPORATION

## Safety Precautions

---

The following are general safety precautions that are not necessarily related to any specific part or procedure, and do not necessarily appear elsewhere in this publication. These precautions must be thoroughly understood and apply to all phases of operation and maintenance.

### **WARNING**

#### **Keep Away From Live Circuits**

Operating Personnel must at all times observe general safety precautions. Do not replace components or make adjustments to the inside of the test equipment with the high voltage supply turned on. To avoid casualties, always remove power.

### **WARNING**

#### **Shock Hazard**

Do not attempt to remove the RF transmission line while RF power is present.

### **WARNING**

#### **Do Not Service Or Adjust Alone**

Under no circumstances should any person reach into an enclosure for the purpose of service or adjustment of equipment except in the presence of someone who is capable of rendering aid.

### **WARNING**

#### **Safety Earth Ground**

An uninterruptible earth safety ground must be supplied from the main power source to test instruments. Grounding one conductor of a two conductor power cable is not sufficient protection. Serious injury or death can occur if this grounding is not properly supplied.

### **WARNING**

#### **Resuscitation**

Personnel working with or near high voltages should be familiar with modern methods of resuscitation.

### **WARNING**

#### **Remove Power**

Observe general safety precautions. Do not open the instrument with the power on.

## Safety Symbols

### WARNING

Warning notes call attention to a procedure, which if not correctly performed, could result in personal injury.

### CAUTION

Caution notes call attention to a procedure, which if not correctly performed, could result in damage to the instrument.

**Note:** *Calls attention to supplemental information.*

## Warning Statements

The following safety warnings appear in the text where there is danger to operating and maintenance personnel, and are repeated here for emphasis.

### WARNING

Leaking RF energy is a potential health hazard. Never attempt to connect or disconnect equipment from the transmission line while RF power is being applied. Severe burns, electrical shock, or death can occur.

See page 7.

### WARNING

Do not touch the center conductor of the power monitor ports while RF power is being applied.

See page 8.

### WARNING

Disconnect the unit from the RF power source and the AC line before any disassembly. The potential for electrical shock exists.

See page 12 and 20.

### WARNING

Shock hazard. Remove AC power before attempting to service the equipment.

See page 22.

## Caution Statements

---

The following equipment cautions appear in the text and are repeated here for emphasis.

**CAUTION**

The input voltage must be clean and stable. Be sure that the input voltage does not surge and does not contain spikes. Failure to comply may result in permanent damage to the instrument.

See page 8.

**CAUTION**

The maximum input voltage differential is 72 V. Do not apply an input voltage differential greater than 72 volts. Failure to comply may result in permanent damage to the instrument.

See page 8.

**CAUTION**

The +15V supply should only be used to power the ACM Panel.  
Do not connect anything else to the power supply.

See page 12.

**CAUTION**

Do not use harsh or abrasive detergents for cleaning.

See page 20.

**CAUTION**

The +15V supply should only be used to power the ACM Panel.  
Do not connect anything else to the power supply.

See page 22.

## **Safety Statements**

---

### **USAGE**

ANY USE OF THIS INSTRUMENT IN A MANNER NOT SPECIFIED BY THE MANUFACTURER MAY IMPAIR THE INSTRUMENT'S SAFETY PROTECTION.

### **USO**

EL USO DE ESTE INSTRUMENTO DE MANERA NO ESPECIFICADA POR EL FABRICANTE, PUEDE ANULAR LA PROTECCIÓN DE SEGURIDAD DEL INSTRUMENTO.

### **BENUTZUNG**

WIRD DAS GERÄT AUF ANDERE WEISE VERWENDET ALS VOM HERSTELLER BESCHRIEBEN, KANN DIE GERÄTESICHERHEIT BEEINTRÄCHTIGT WERDEN.

### **UTILISATION**

TOUTE UTILISATION DE CET INSTRUMENT QUI N'EST PAS EXPLICITEMENT PRÉVUE PAR LE FABRICANT PEUT ENDOMMAGER LE DISPOSITIF DE PROTECTION DE L'INSTRUMENT.

### **IMPIEGO**

QUALORA QUESTO STRUMENTO VENISSE UTILIZZATO IN MODO DIVERSO DA COME SPECIFICATO DAL PRODUTTORE LA PROZIONE DI SICUREZZA POTREBBE VENIRNE COMPROMESSA.

## **SERVICE**

SERVICING INSTRUCTIONS ARE FOR USE BY SERVICE - TRAINED PERSONNEL ONLY. TO AVOID DANGEROUS ELECTRIC SHOCK, DO NOT PERFORM ANY SERVICING UNLESS QUALIFIED TO DO SO.

## **SERVICIO**

LAS INSTRUCCIONES DE SERVICIO SON PARA USO EXCLUSIVO DEL PERSONAL DE SERVICIO CAPACITADO. PARA EVITAR EL PELIGRO DE DESCARGAS ELÉCTRICAS, NO REALICE NINGÚN SERVICIO A MENOS QUE ESTÉ CAPACITADO PARA HACERLO.

## **WARTUNG**

ANWEISUNGEN FÜR DIE WARTUNG DES GERÄTES GELTEN NUR FÜR GESCHULTES FACHPERSONAL.

ZUR VERMEIDUNG GEFÄHRLICHE, ELEKTRISCHE SCHOCKS, SIND WARTUNGSARBEITEN AUSSCHLIEßLICH VON QUALIFIZIERTEM SERVICEPERSONAL DURCHZUFÜHREN.

## **ENTRETIEN**

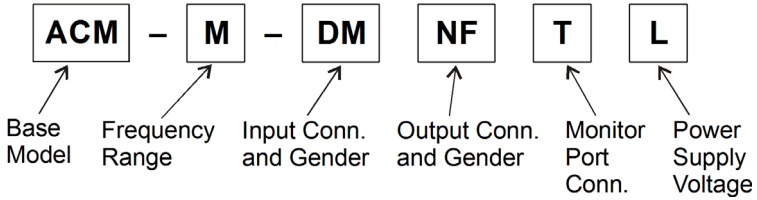
L'EMPLOI DES INSTRUCTIONS D'ENTRETIEN DOIT ÊTRE RÉSERVÉ AU PERSONNEL FORMÉ AUX OPÉRATIONS D'ENTRETIEN. POUR PRÉVENIR UN CHOC ÉLECTRIQUE DANGEREUX, NE PAS EFFECTUER D'ENTRETIEN SI L'ON N'A PAS ÉTÉ QUALIFIÉ POUR CE FAIRE.

## **ASSISTENZA TECNICA**

LE ISTRUZIONI RELATIVE ALL'ASSISTENZA SONO PREVISTE ESCLUSIVAMENTE PER IL PERSONALE OPPORTUNAMENTE ADDESTRATO. PER EVITARE PERICOLOSE SCOSSE ELETTRICHE NON EFFETTUARE ALCUNA RIPARAZIONE A MENO CHE QUALIFICATI A FARLA.

## About This Manual

Sample Model **ACM-M-DMNFTL**  
 470 – 960 MHz ACM with male 7/16 input, female N output,  
 female TNC monitor ports, requiring a low voltage power supply



Base Model	Frequency Range (MHz)		Input and output RF Connectors		Monitor Port Connectors		Power Supply Voltage	
ACM	L0	108 – 138	NM	Male N	N	Female N	L	+11 to +26 VDC
ACM 500	L1	136 – 225	NF	Female N	T	Female TNC	H	± 36 to 72 VDC
	L2	225 – 520	DM	Male 7/16 DIN	B	Female BNC		
	M	470 – 960	DF	Female 7/16 DIN				
	H	960 – 2400						

**Exception:** Model ACM-L2-DFDFTL-12SP and ACM-L2-DFDFTH-48SP have no other variations.

**Exception:** Models in ACM500 series do not support frequency range L0 and H and any of its variations.

## **Changes to this Manual**

---

We have made every effort to ensure this manual is accurate. If you discover any errors, or if you have suggestions for improving this manual, please send your comments to our Solon, Ohio factory. This manual may be periodically updated. When inquiring about updates to this manual refer to the part number and revision on the title page.

## **Chapter Layout**

---

**Introduction** — Identifies the parts and functions of the ACM.

**Theory of Operation** — Describes the ACM's alarm options.

**Installation** — Provides instructions for installing the ACM at a site, as well as detailed information on the cable connections.

**Operating Instructions** — Explains computer commands for controlling the ACM and describes operation of the optional PCTool software.

**Maintenance** — Lists routine maintenance tasks for the ACM, as well as troubleshooting information for common problems. Specifications and parts lists are also included.



# TABLE OF CONTENTS

<b>Safety Precautions</b> .....	<b>ii</b>
Safety Symbols .....	iii
Warning Statements .....	iii
Caution Statements .....	iv
Safety Statements .....	v
<b>About This Manual</b> .....	<b>vii</b>
Changes to this Manual .....	viii
Chapter Layout .....	viii
<b>Chapter 1 Introduction</b> .....	<b>1</b>
Features .....	1
Items Supplied .....	2
Optional Accessories .....	2
Component Description .....	3
<b>Chapter 2 Theory of Operation</b> .....	<b>5</b>
Alarm Response .....	5
Alarm Reset .....	5
Alarm Latching .....	5
VSWR Alarm .....	5
Alarm on Zero Power .....	6
High Power Alarm .....	6
Low Power Alarm .....	6
Push-to-Talk .....	6
<b>Chapter 3 Installation</b> .....	<b>7</b>
Unpacking and Inspection .....	7
Mounting .....	7
Cable Connections .....	7
Power/Alarm Connector .....	8
RS-232 Connector .....	11
Panel Mount .....	12
Installation .....	12
Power Supply .....	12
RS-232 Port Setup .....	12
PCTool Software .....	13
Computer Requirements .....	13
<b>Chapter 4 Operating Instructions</b> .....	<b>14</b>

- PCTool Software ..... 14
  - Main Screen ..... 14
  - Com Settings ..... 15
  - Alarm Options ..... 15
  - Push-to-Talk ..... 18
- Terminal Commands ..... 19
  - “T” ..... 19
  - “C” ..... 19
  - “A” ..... 19
- Chapter 5 Maintenance ..... 20**
  - Inspection and Cleaning ..... 20
  - Troubleshooting ..... 21
  - Rack Mount Wiring ..... 22
  - Customer Service ..... 24
  - Specifications ..... 25
    - General ..... 25
    - Frequency Range ..... 26
    - RF Power Range ..... 26
    - Accuracy ..... 26
    - Insertion Loss, Max. .... 26
    - VSWR, Max. .... 26
  - Replacement Parts ..... 27
- Limited Warranty ..... 28**

Designed for 50 ohm coaxial transmission lines, the Bird Antenna & Cable Monitor is the solution for monitoring transmission antenna systems. Service providers and end users can rely on it to keep their critical sites up and running. Designed to detect antenna and cable faults that transmitter-internal VSWR monitors may not detect, it also provides accurate in-line power measurement functionality.

## Features

---

- Measures forward and reflected power as well as VSWR and Return Loss.
- Measures true average power of pulses with high peak-to-average ratios - works with any modulation!
- Worldwide systems include Tetra, Cellular, and PCS with digital or analog modulation. Other applications include 3G, AMPS, Broadcast, CDMA, CDMA 2000, DCS, EDGE, Government, GPRS, GSM, iDEN, Industrial, NPSPAC, Microwave, Military, Paging, Public Safety, Rail, SMR, TDMA, Tetrapol, Trunking, UHF, Utilities, VHF, W-CDMA, and WLL
- When monitoring transmitter output power, alarms available for low or high power.
- Accurately monitors antenna and cable system VSWR. Alarm triggered if antenna or cable fails.
- Integral coupler measures small changes in VSWR through high feeder and interface losses. High directivity maximizes measurement accuracy.
- Sampling ports allow signal measurements without requiring system downtime.
- Excellent passive intermod allows the unit to be inserted into multichannel systems with a single Tx/Rx antenna with no desensing or degradation of receiver performance.
- Can be rack mounted at the output of transmitter combiner or linear power amplifier.
- Local or remote setup and operation via RS-232 port and PCTool software. (For other telemetry options, such as TCP/IP, contact the factory)

## Items Supplied

---

- ACM Unit
- Instruction Manual

## Optional Accessories

---

Refer to "[Replacement Parts](#)" on [page 27](#) for part numbers of accessories.

**Digital Display** — Displays the ACM status and provides a low voltage (+15 VDC) power supply. Includes a power cord and 50 foot, 9 pin and 15 pin cables.

**PCTool Software** — PC software for data display, alarm monitoring, and setting alarm options

**DB-15 Power/Alarm Cables** — Connects the Antenna Monitor to a power supply and to external controllers. 50 feet long with male/female connectors. Refer to [Figure 3 on page 9](#) and [Figure 5 on page 10](#) for pin layout.

**DB-15 Interface Connector** — Allows easy custom data cable connections to the ACM.

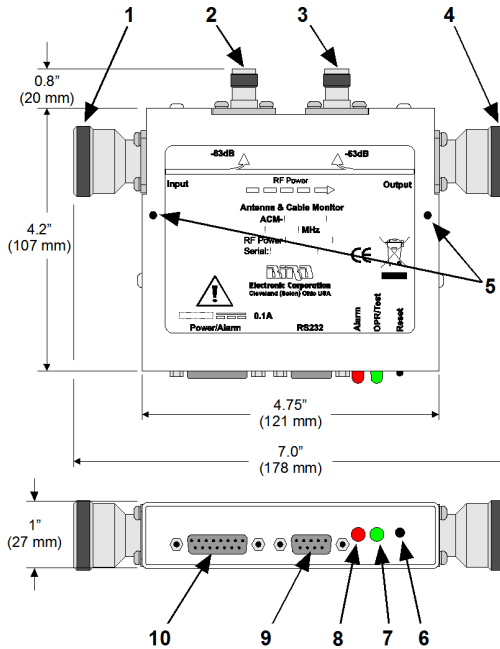
**9 pin RS-232 PC Interface Cables** — Connects the Antenna Monitor to a PC. Available in either 10 or 50 foot lengths, with male/female connectors. Refer to [Figure 7 on page 11](#) for pin layout.

**Rack Mount** — The Rack Mount Kit allows up to two ACMs to be installed in a standard (2U) panel mount. They are secured with locator holes and a Velcro strap. Power is provided through 15-pin parallel cables, connected to a terminal strip at the factory. The ACM-RACKU includes a +15V power supply, while the ACM-RACK requires a 48V customer-provided power supply. [Figure 2](#) lists dimensions and highlights important components.

**Note:** *Model ACM-L2-DFDFTL-12SP cannot be used with the rack mount option.*

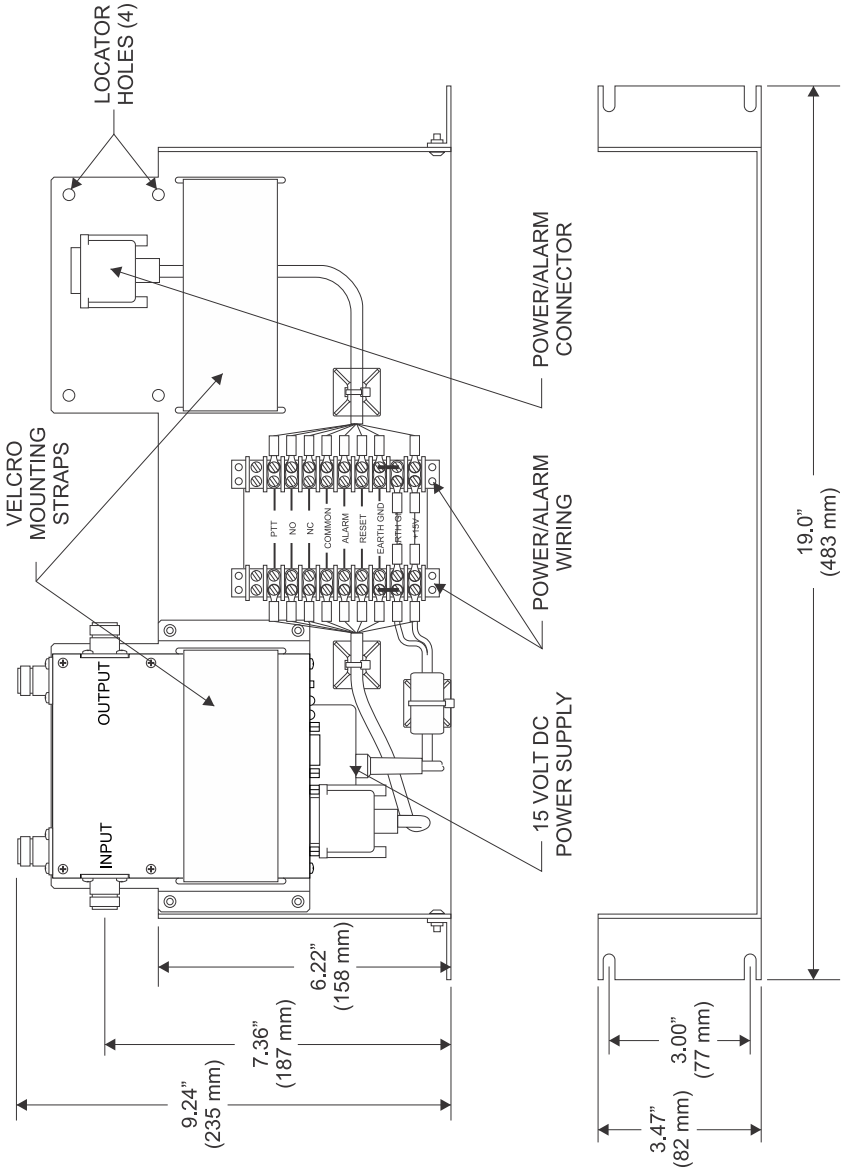
## Component Description

Figure 1 Antenna & Cable Monitor Outline



1	RF Input	Connect to the amplifier or combiner
2	Forward Monitor Port	Samples the forward traveling wave
3	Reflected Monitor Port	Samples the reflected wave
4	RF Output	Connect to the antenna or feeder
5	Mounting Holes	Four holes, two top and two bottom, for positioning the ACM on a rack. Supplied with 4-40 screws, will fit M3 holes.
6	Reset Switch	Press to reset the alarm. If an alarm trigger is still present, the alarm will reactivate
7	Operation/Test LED	Green LED that lights when the unit is powered
8	Alarm LED	Red LED that lights when an alarm is triggered
9	RS-232 Serial Port	9 pin female connector. Interface to a PC using a male 9 pin RS-232 cable
10	Power/Alarm Parallel Port	15 pin female connector (15 pin male connector on models ACM-L2-DFDFTL-12SP and ACM-L2-DFDFTH-48SP only). Connects to the power supply using a male 15 pin cable. Also used for remote operation.

Figure 2 Panel Mount Outline



## Alarm Response

---

When an alarm is triggered, the Bird Antenna & Cable Monitor turns on the alarm LED and activates a Form C dry contact relay.

The alarm relay defaults to fail/safe. That is, the alarm activates when the relay is not energized or power is lost. However, the PCTool software can configure the alarm to either energize or de-energize in response to an alarm.

## Alarm Reset

---

- Alarms can be reset locally with the reset switch.
- Alarms are reset when the reset pin on the Power/Alarm port is activated by a TTL compatible logic low signal (0 to 0.8 VDC).
- The PCTool can reset the unit through the RS-232 port by sending a "Reset Alarm" command.

## Alarm Latching

---

The alarm defaults to latching operation. In this mode, the alarm will stay active until reset. In non-latching mode, the alarm will reset automatically about forty seconds after the trigger condition is corrected.

## VSWR Alarm

---

The ACM continuously monitors forward and reflected power. From the power measurements, the VSWR is calculated and compared to the allowed maximum (default of 1.5 to 1). Based on the results of the comparison, possible actions include:

- No alarm is activated if the VSWR is less than the maximum, or if the VSWR alarm is disabled.
- If the VSWR is equal to or slightly greater than the maximum, additional measurements are accumulated to determine a trend. If reverse power is increasing, an alarm is triggered. If the reverse power is stable, measurements continue until a trend is established. An alarm

will be triggered if the VSWR exceeds the maximum for more than thirty seconds.

- If the VSWR is much greater than the maximum then an alarm condition is triggered immediately.

## **Alarm on Zero Power**

---

When the forward power is very small (< 2.5% of full scale), the measured VSWR becomes large due to the noise floor of the sensor. Under these conditions, the VSWR level is meaningless. When the zero power alarm is disabled, the VSWR will not be monitored at these low powers.

## **High Power Alarm**

---

When the high power alarm is enabled, the forward power is continuously monitored. The alarm trigger is a percentage of the Monitor's full scale power, from 0 – 125%. If the forward power is greater than the trigger level, an alarm is triggered.

## **Low Power Alarm**

---

When the low power alarm is enabled, the forward power is continuously monitored. The alarm trigger is a percentage of the Monitor's full scale power, from 0 – 125%. If the forward power is less than the trigger level, an alarm is triggered.

## **Push-to-Talk**

---

The low power alarm and the VSWR alarm can falsely trigger when the transmitter is not keyed. The Push-to-Talk feature uses a logic input from the transmitter to control when alarm monitoring is active. In order to prevent false alarms while monitoring for low power and high VSWR, the Push-to-Talk feature must be enabled.



This chapter provides information for preparing the Bird Antenna & Cable Monitor for use.

## Unpacking and Inspection

---

1. Carefully inspect the shipping container for signs of damage.

**Note:** *If damage is noticed, do not unpack the unit. Immediately notify the shipping carrier and Bird Electronic Corporation.*

2. If the shipping container is not damaged, unpack the unit.

**Note:** *Save the packing material in case the unit needs to be shipped again.*

3. Inspect all of the components for visible signs of damage.

**Note:** *Immediately notify the shipping carrier and Bird Electronic Corporation of equipment damage or missing parts.*

The Bird ACM is shipped complete and ready for use upon receipt. After unpacking and inspecting the unit, it is ready to be installed.

### WARNING

Leaking RF energy is a potential health hazard. Never attempt to connect or disconnect equipment from the transmission line while RF power is being applied. Severe burns, electrical shock, or death can occur.

## Mounting

---

Mount the ACM in the feeder line between the combiner and the antenna. Make sure that the alarm LED and reset button are accessible, and that the connecting cables have proper clearance.

## Cable Connections

---

When connecting the Bird ACM to RF power, use 50 ohm coaxial cable suitable for the frequency and power level of operation. The cable connector should mate with the connector on the unit.

Connect the amplifier or combiner to the Monitor's input. Connect the antenna or feeder to the output.

**WARNING**

Do not touch the center conductor of the power monitor ports while RF power is being applied.

To monitor the RF waveform, connect the forward and reflected power monitor ports to an appropriate power sensor or meter.

**Note:** *If a power monitor port is not being used, terminate it with a 50Ω load.*

## Power/Alarm Connector

---

Connect the external power supply here. Pin numbers and descriptions are given in [Figure 3](#) and [Figure 5](#).

**CAUTION**

The input voltage must be clean and stable. Be sure that the input voltage does not surge and does not contain spikes. Failure to comply may result in permanent damage to the instrument.

Low voltage models (ACM-x-xxxxxL and ACM500-x-xxxxxL) require +11 to +26 VDC power @ 0.1 A (nominal +15 VDC).

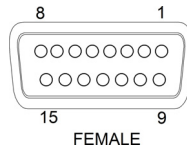
**Note:** *Exception: Model ACM-L2-DFDFTL-12SP is a low voltage model but it requires a +9 to +18 VDC (12 V nominal) @ 0.13 mA. Either terminal (10 or 11) may be connected to DC input ground, as dictated by the power supply requirements.*

**CAUTION**

The maximum input voltage differential is 72 V. Do not apply an input voltage differential greater than 72 volts. Failure to comply may result in permanent damage to the instrument.

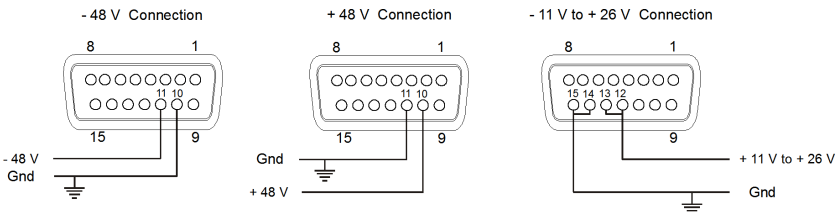
High voltage models (ACM-x-xxxxxH and ACM500-x-xxxxxH) require 36 to 72 VDC (48 V nominal) @ 0.1 A. Either terminal (10 or 11) may be connected to DC input ground, as dictated by the power supply requirements.

**Figure 3 DB-15 Power/Alarm Connector, Female**

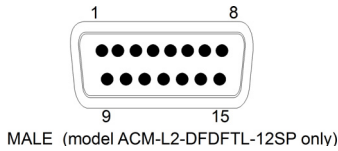


Pin	Description
1	Relay, normally closed contact (closed when relay is not energized) (open when there is no alarm)
2	Relay, common contact
3	TTL compatible alarm, 0 to $\geq 4.0$ VDC with a 10k load when the alarm is active
4	PTT input, +5V to +24V to activate, 0V or open to deactivate
5	TTL compatible reset, 0 to +0.8 VDC resets alarm
6-8	Internal connection
9	Relay, normally open contact (open when relay is not energized) (closed when there is no alarm)
10	DC input, 36 to 72 VDC, + terminal (ACM-x-xxxxxH models only). See <a href="#">Figure 4</a> .
11	DC input, 36 to 72 VDC, – terminal (ACM-x-xxxxxH models only). See <a href="#">Figure 4</a> .
12-13	DC input, +11 to +26 VDC (ACM-x-xxxxxL models only). Pins 12 and 13 are internally connected (see <a href="#">Figure 4</a> ).
14-15	DC input and signal ground. Pins 14 and 15 are internally connected (see <a href="#">Figure 4</a> ).

**Figure 4 Power/Alarm Connector Wiring, Female**

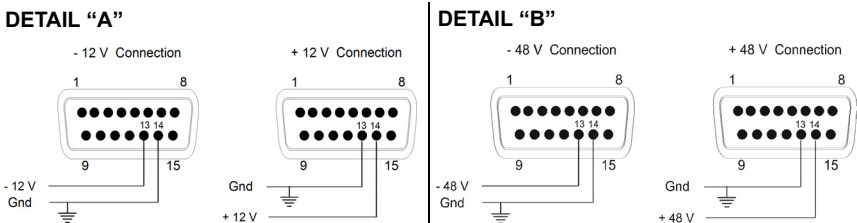


**Figure 5 DB-15 Power/Alarm Connector, Male**



Pin	Description
1-3	Internal connection
4	TTL compatible reset, 0 to +0.8 VDC resets alarm
5	PTT input, +5V to +24V to activate, 0V or open to deactivate
6	TTL compatible alarm, 0 to $\geq 4.0$ VDC with a 10k load when the alarm is active
7	Relay, common contact
8	Relay, normally closed contact (closed when relay is not energized) (open when there is no alarm)
9-10	DC input and signal ground
11-12	No connection (model ACM-L2-DFDFTL-12SP only)
13	DC input, 9 to 18 VDC, - terminal (model ACM-L2-DFDFTL-12SP only). See DETAIL "A" in <a href="#">Figure 6</a> .
	DC input, 36 to 72 VDC, - terminal (model ACM-L2-DFDFTL-48SP only). See DETAIL "B" in <a href="#">Figure 6</a> .
14	DC input, 9 to 18 VDC, + terminal (model ACM-L2-DFDFTL-12SP only). See DETAIL "A" in <a href="#">Figure 6</a> .
	DC input, 36 to 72 VDC, + terminal (model ACM-L2-DFDFTL-48SP only). See DETAIL "B" in <a href="#">Figure 6</a> .
15	Relay, normally open contact (open when relay is not energized) (closed when there is no alarm)

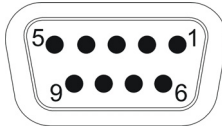
**Figure 6 Power/Alarm Connector Wiring, Male**



## RS-232 Connector

The RS-232 connector carries ASCII data between the Antenna Monitor and a display panel or PC. If a PC is connected to the display front panel, it is also routed to this connector. Pin numbers and connection descriptions are given in [Figure 7](#).

**Figure 7** DB-9 RS-232 Connector



Pin	Description
1	Carrier Detect, always > +5 VDC
2	Transmit Output, RS-232 data signal
3	Receive Input, RS-232 data signal
4	Data Set Ready Input, connected but not used
5	Data Signal Ground
6	Data Terminal Ready Output, connected but not used
7	Clear-To-Send, shorted internally to Ready-To-Send
8	Ready-To-Send, shorted internally to Clear-To-Send
9	Ring Indicator, no connection

## Panel Mount

---

### WARNING

Disconnect the unit from the RF power source and the AC line before any disassembly. The potential for electrical shock exists.

### CAUTION

The +15V supply should only be used to power the ACM Panel. Do not connect anything else to the power supply.

## Installation

---

To install a Bird Antenna Monitor in the panel mount, follow these instructions (Refer to [Figure 2 on page 4](#)):

1. Unbuckle the Velcro strap and move the power/alarm connector out of the way.
2. Place the ACM on the panel so that the screws on the bottom of the Monitor fit into the locator holes on the panel.

**Note:** *The ACM should lock into place.*

3. Use the strap to secure the ACM.
4. Plug the power/alarm connector into the power/alarm parallel port on the ACM.
5. Make RF and RS-232 connections as described in this chapter.

## Power Supply

---

The ACM–RACKU includes a +15 VDC supply already connected to the terminal strip.

The ACM–RACK requires a customer-provided power supply. Connect the supply according to the manufacturer's instructions ("[Rack Mount Wiring](#)" on [page 22](#) for details on the panel wiring configuration).

## RS-232 Port Setup

---

The RS-232 port is configured for 9600 baud, 8 data bits, 1 stop bit and no parity. This configuration is fixed in the firmware and cannot be modified. Operate the serial interface as follows:

- Connect the Bird Antenna Monitor to the computer's serial port with a DB-9 cable. *Do not use a null modem adapter.* The port is configurable from within the PCTool software.

- To use the Bird PCTool software, install it on the computer and start the application. Refer to "[PCTool Software](#)" on [page 14](#) for information about using the program.
- To use a terminal program, configure it for 9600 baud, 8 data bits, 1 stop bit, no parity, and no handshake. Set the preferences so that echo is off and line feeds are not appended to output transmission. The commands available are detailed in "[Terminal Commands](#)" on [page 19](#).

## PCTool Software

---

### Computer Requirements

---

The Bird PCTool software will run on any computer running Windows NT or Windows 95/98/2000. To install and run the program, your computer system must meet or exceed the requirements listed below:

486 or better CPU (66 MHz or better recommended)

1 MB of free memory

Hard Disk Drive

CD-ROM Drive

Follow the instructions on the CD provided to install the software.

The PCTool may also be downloaded from the Bird Technologies Group website at :

*[www.birdrf.com](http://www.birdrf.com), search for ACM PC Tool.*

## PCTool Software

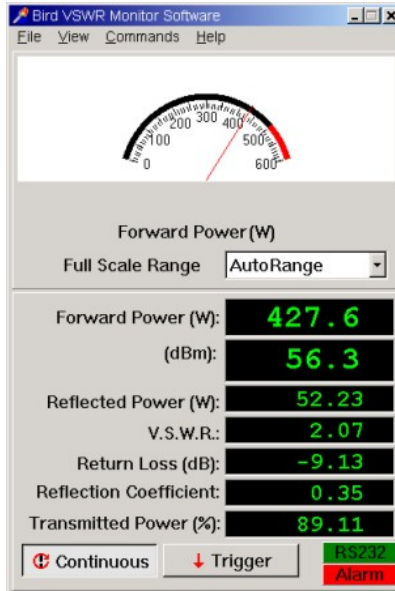
---

### Main Screen

---

The PCTool communicates with and configures the Bird Antenna & Cable Monitor. It displays forward and reverse power along with VSWR, return loss, match efficiency and transmitted power. [Figure 8](#) shows a sample of the display screen. Refer to the software “Help” file for specific instructions.

**Figure 8** *Sample Display*



The main screen has two buttons at the bottom, “Trigger” and “Continuous”. Clicking on these will trigger readings. “Trigger” will display a single reading, while “Continuous” will take a new reading every second.



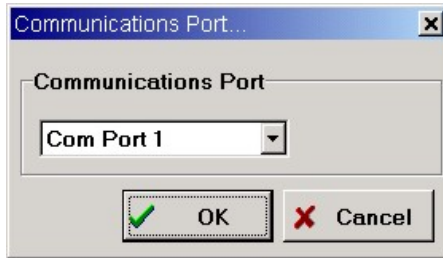
---

## Com Settings

---

The PCTool software must be set to use the correct Com Port to communicate with the Antenna Monitor. The default is Com Port 1. To change the Com Port, select the correct one from the “View>Comm Port” menu, shown in [Figure 9](#) below.

**Figure 9** Com Menu



---

## Alarm Options

---

Three alarms can be configured from the software. All alarms are configured from the “View>Options” menu, shown in [Figure 10 on page 16](#).

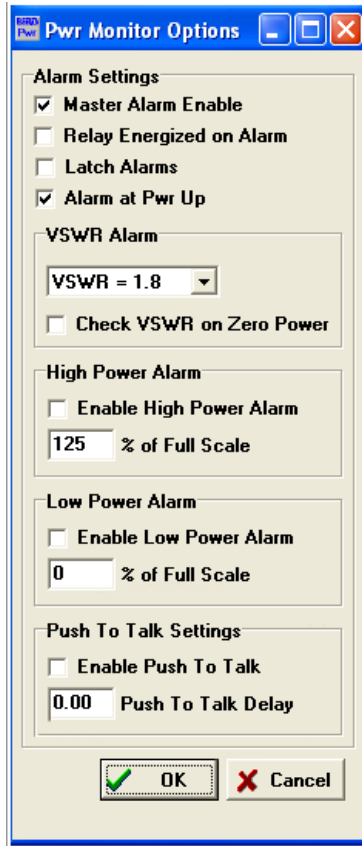
- High VSWR: Calculated VSWR exceeds a setpoint.
- High Forward Power: Measured power exceeds a setpoint.
- Low Forward Power: Measured power is less than a setpoint.

**Note:** *Some models are not equipped with all alarm variations.*

**Master Alarm Enable** — Allows the alarms to work. When this checkbox is *unchecked*, all alarms will be disabled. When it is *checked*, the VSWR alarm will automatically be enabled while “Alarm on Zero Power”, “High Power Alarm”, and “Low Power Alarm” will be on or off depending on their checkboxes.

**Relay Energized on Alarm** — The energized state of the relay can be set. When this checkbox is unchecked, the relay will be de-energized when an alarm is detected and energized when there is no alarm. With this setting, the alarm is fail-safe. When it is checked, the relay will be energized when an alarm is detected and de-energized when there is no alarm.

Figure 10 Options Menu



**Latch Alarms** — Sets whether the alarm will reset automatically in the absence of an alarm condition. When this checkbox is *unchecked*, if an alarm trigger is corrected the alarm will reset after a forty second delay. When it is *checked*, the alarm must be manually reset.

**Alarm at Power (Pwr) Up** — At power up, before the instrument is ready to take measurements, the microcontroller resets the circuitry to the default condition and then performs internal initialization tasks (such as memory test, hardware setup, and reading EEPROM parameters). *Check* the Alarm at Pwr Up box to have the alarm relay set (enabled) during the microcontroller initialization time. This is the default setting. *Uncheck* the Alarm at Pwr Up box to disable the alarm during the microcontroller initialization time.

**Note:** *When the Alarm at Pwr Up feature is disabled, the alarm relay may set for a few milliseconds during initialization.*

**VSWR Alarm** — Adjustable from 1.3 to 2.5 by increments of 0.1. To allow the VSWR alarm to trigger even at low forward power (< 2.5% of full scale power), check the “Alarm on Zero Power” checkbox.

While the VSWR trip point can now be set out to 2.5, the instrument cannot always measure VSWR above 1.9. This is due to the large amount of reflected power caused at higher VSWRs. The maximum VSWR that can be physically measured is determined by the full scale ratio of the forward and reflected detectors. This ratio is 10:1. The maximum measurable VSWR occurs when the reflected channel is near its limit. The following table shows the maximum possible VSWR measurement as a function of percentage of full scale forward input power. Use this table as a guide to determine the VSWR trip point.

Percentage Full Scale	Max VSWR
50%	3.00
55%	2.82
60%	2.68
65%	2.56
70%	2.46
75%	2.38
80%	2.31
85%	2.24
90%	2.19
95%	2.14
100%	2.09

**High Power Alarm** — Adjustable from 0 to 125% of the ACM’s full scale power. The alarm setpoint is entered as the % of full scale.

***Example** - A 100W full scale unit and an alarm is needed when the forward power exceeds 75 W, the alarm setpoint would be 75/100 x 100 or 75%. Enter “75” into the data field and check the “Enable High Power Alarm” checkbox.*

**Low Power Alarm** — Set in the same way as the High Power Alarm, however this alarm will trigger when the forward power is *less than* the alarm setpoint.

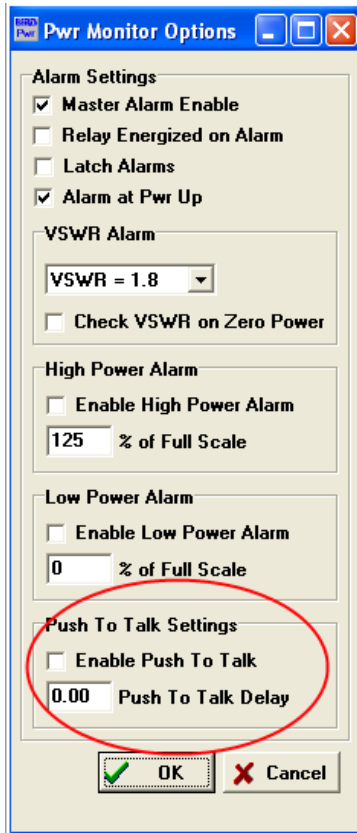
## Push-to-Talk

### Setting Push-to-Talk

1. Open the Power Monitor Options dialog.
2. Do one of the following:
  - Check the Enable checkbox to turn the Push-to-Talk feature on.
  - Uncheck the Enable checkbox to turn the Push-to-Talk feature off.
3. Enter any value for the time up to 14 sec.

**Note:** The time actually programmed on the ACM will be a multiple of 156.25 ms. For this reason, the time displayed will be slightly different from the time set. The actual delay from the PTT signal is uncertain because the PTT signal is asynchronous to the internal measurement samples. The uncertainty is +/- 156.25 ms.

Figure 11 Push-to-Talk



## Terminal Commands

---

There are three commands which can be sent when the Bird Antenna Monitor is connected to a terminal.

### “T”

---

The “T” command will cause the unit to echo a single measurement. The format is:

```
nnn.n,nn.nnXX<CR><LF>
```

That is, three digits of forward power, a decimal point, a fourth digit of forward power, a comma, followed by two digits of reverse power, a decimal point, and two digits of reverse power.

The first character following will be “A” if an alarm has been triggered until the alarm is reset, and will be blank if there is no alarm. The second character will be “O” if “Alarm on Zero Power” is disabled, and “1” if “Alarm on Zero Power” is enabled.

### “C”

---

The “C” command will cause the unit to echo measurements repeatedly. The format is identical to the “T” command. The “C” command can be interrupted at any time by sending the “T” command.

### “A”

---

The “A” command will reset the alarm. If an alarm condition is still present, the alarm will turn back on after being reset.

This chapter contains troubleshooting instructions, part information, and specifications for the Bird Antenna & Cable Monitor.

## Inspection and Cleaning

---

This unit requires only simple and routine maintenance.

### WARNING

Disconnect the unit from the RF power source and the AC line before any disassembly. The potential for electrical shock exists.

### CAUTION

Do not use harsh or abrasive detergents for cleaning.

1. Wipe off dust and dirt regularly.

**Note:** *Use a soft, clean cloth dampened with mild detergent.*

2. Check connectors, connector pins, and cables for damage.

**Note:** *If needed, clean the connectors using a self-drying contact cleaner that leaves no residue.*

## Troubleshooting

The Bird Antenna Monitor has no operator serviceable parts. Any required service must be performed at an authorized service facility.

The table below contains troubleshooting information for problems which can occur during normal operation. This manual cannot list all malfunctions that may occur, or their corrective actions. If a problem is not listed or is not corrected by the listed actions, notify a qualified service center.

<b>Problem</b>	<b>Possible Cause</b>	<b>Correction</b>
Operation/Test LED does not illuminate	No DC power	Check power source.
	Defective LED	Return the unit to an authorized service center.
Alarm LED does not illuminate	Defective LED	Return the unit to an authorized service center.
High VSWR	Dirty connectors	Clean connectors.
	Defective connectors	Replace connectors.
	Shorted or open transmission line	Have the line serviced.

## Rack Mount Wiring

The power/alarm connectors for the Bird ACM Rack Mount are provided wired to the terminal strips. [Figure 12](#), [Figure 13](#), and [Figure 14](#) show the wiring schematics for 15V, 12V, and 48V respectively.

**WARNING**

Shock hazard. Remove AC power before attempting to service the equipment.

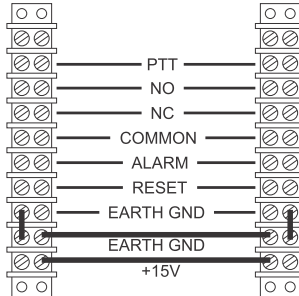
**CAUTION**

The +15V supply should only be used to power the ACM Panel.  
Do not connect anything else to the power supply.

Note the following, which apply to both Rack Mount styles:

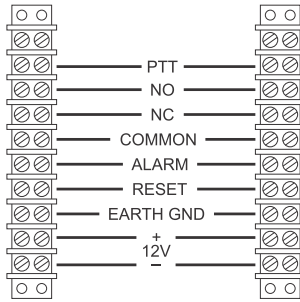
- The top terminal is not used.
- For either model, the power/alarm connector is wired identically on both terminal strips.
- The 15V, 12V, and 48V connectors have different connection callouts. Be sure to use the correct wiring schematic for each specific model.

**Figure 12 15V Wiring Schematic**

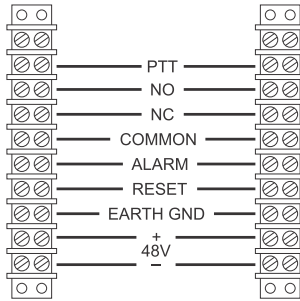




**Figure 13 12V Wiring Schematic**



**Figure 14 48V Wiring Schematic**



## **Customer Service**

---

Any maintenance or service procedure beyond the scope of those in this chapter should be referred to a qualified service center.

If the unit needs to be returned for any reason, request an Return Material Authorization (RMA) through the Bird Technologies website. All instruments returned must be shipped prepaid and to the attention of the RMA number.

### **Bird Service Center**

30303 Aurora Road  
Cleveland (Solon), Ohio 44139-2794  
Fax: (440) 248-5426  
E-mail: *bsc@birdrf.com*

For the location of the Sales Office nearest you, visit our Web site at:  
*<http://www.birdrf.com>*

## Specifications

### General

<b>Directivity, Min.</b> 108 – 960 MHz 960 – 2400 MHz	30 dB 26 dB
VSWR Alarm Setpoint	1.3:1.0 to 2.5:1.0 by 0.1:1.0 steps. Refer to " <a href="#">VSWR Alarm</a> " on page 17 for information about power limitations.
Alarm Relay	Dry, form C. Common, normally open, & normally closed contacts.
Relay Contact Rating	100 VDC @ 0.5 A
Visual Alarm	Red LED will light to indicate an alarm
Alarm Stimulus	VSWR setpoint exceeded, response time proportional to overload
Alarm Reset	Local mechanical reset switch Remote input (Reset if VDC = 0 to +0.8 V)
RF Connectors	Male or Female, N or 7/16 DIN
Monitor Port Connectors	Female N, TNC, or BNC
Monitor Port Coupling	-63 dB nominal
Passive Intermodulation Products	< -130 dBc
<b>RS-232 Serial Port</b> Connector Protocol	Female DB-9 RS-232, 9600 baud, no parity, 8 data bits, 1 stop bit, no handshake
Power/Alarm Parallel Port	Female DB-15 connector
<b>Power Requirements</b> ACM-x-xxxxxL ACM500-x-xxxxxL ACM-x-xxxxxH ACM500-x-xxxxxH ACM-L2-DFDFTL-12SP	+11 to +26 VDC @ 0.1 A +11 to +26 VDC @ 0.1 A ± (36 to 72) VDC @ 0.1 A ± (36 to 72) VDC @ 0.1 A +9 to +18 VDC @ 0.13 A
<b>Temperature</b> Operating Storage	0 to 50 °C (32 to 122 °F) -20 to +80 °C (-4 to +176 °F)
Altitude, Max.	3000 m (10,000 ft.)
Humidity, Max.	95% non-condensing
Dimensions, Nominal, without connectors	4.6" L x 4.8" W x 1.2" H (117 x 122 x 30 mm)
Weight, Max.	2 lbs. (0.9 kg)

### Frequency Range

---

<b>ACM500-</b>	<b>ACM-</b>	
----	L0-xxxxxx	108 – 138 MHz
L1	L1-xxxxxx	136 – 225 MHz
L2	L2-xxxxxx	225 – 520 MHz
M	M-xxxxxx	470 – 960 MHz
----	H-xxxxxx	960 – 2400 MHz

### RF Power Range

---

ACM-L0-xxxxxx	5 - 200 W
All Other ACM models	2.5 – 100 W
ACM500-xx-xxxxxx	12.5 – 500 W

### Accuracy

---

<b>ACM500</b>	<b>ACM-</b>	
----	L0	± 8%
L1	L1	± 10%
L2	L2	± 8%
M	M	± 5%
----	H	± 5%

### Insertion Loss, Max.

---

108 – 960 MHz	0.1 dB
960 – 2400 MHz	0.15 dB

### VSWR, Max.

---

<b>N Connectors</b>	
108 – 960 MHz	1.07:1
960 – 2400 MHz	1.1:1
<b>7/16 DIN Connectors</b>	
108 – 960 MHz	1.07:1
960 – 2000 MHz	1.1:1
2000 – 2400 MHz	1.2:1

## Replacement Parts

Description	Part Number
Instruction Manual	920-ACM
PCTool Software	7005A970
Rack Mount Kit With 15VDC power supply Without power supply	ACM-RACKU ACM-RACK
<b>9 pin RS-232 Interface Cable</b> 50 ft. 10 ft.	5A2264-09-MF-50 5A2264-09-MF-10
DB-15 Interface Cable, 50 ft., male/female	5A2264-15-MF-50
DB-15 Interface Connector	SUBCON-15/M-SH

# Limited Warranty

All products manufactured by Seller are warranted to be free from defects in material and workmanship for a period of one (1) year, unless otherwise specified, from date of shipment and to conform to applicable specifications, drawings, blueprints and/or samples. Seller's sole obligation under these warranties shall be to issue credit, repair or replace any item or part thereof which is proved to be other than as warranted; no allowance shall be made for any labor charges of Buyer for replacement of parts, adjustment or repairs, or any other work, unless such charges are authorized in advance by Seller.

If Seller's products are claimed to be defective in material or workmanship or not to conform to specifications, drawings, blueprints and/or samples, Seller shall, upon prompt notice thereof, either examine the products where they are located or issue shipping instructions for return to Seller (transportation-charges prepaid by Buyer). In the event any of our products are proved to be other than as warranted, transportation costs (cheapest way) to and from Seller's plant, will be borne by Seller and reimbursement or credit will be made for amounts so expended by Buyer. Every such claim for breach of these warranties shall be deemed to be waived by Buyer unless made in writing within ten (10) days from the date of discovery of the defect.

The above warranties shall not extend to any products or parts thereof which have been subjected to any misuse or neglect, damaged by accident, rendered defective by reason of improper installation or by the performance of repairs or alterations outside of our plant, and shall not apply to any goods or parts thereof furnished by Buyer or acquired from others at Buyer's request and/or to Buyer's specifications. Routine (regularly required) calibration is not covered under this limited warranty. In addition, Seller's warranties do not extend to the failure of tubes, transistors, fuses and batteries, or to other equipment and parts manufactured by others except to the extent of the original manufacturer's warranty to Seller.

The obligations under the foregoing warranties are limited to the precise terms thereof. These warranties provide exclusive remedies, expressly in lieu of all other remedies including claims for special or consequential damages. SELLER NEITHER MAKES NOR ASSUMES ANY OTHER WARRANTY WHATSOEVER, WHETHER EXPRESS, STATUTORY, OR IMPLIED, INCLUDING WARRANTIES OF MERCHANTABILITY AND FITNESS, AND NO PERSON IS AUTHORIZED TO ASSUME FOR SELLER ANY OBLIGATION OR LIABILITY NOT STRICTLY IN ACCORDANCE WITH THE FOREGOING.