

HAND PALLET TRUCK Transpalette Manuelle

Hand Pallet Truck with Digital Scale available

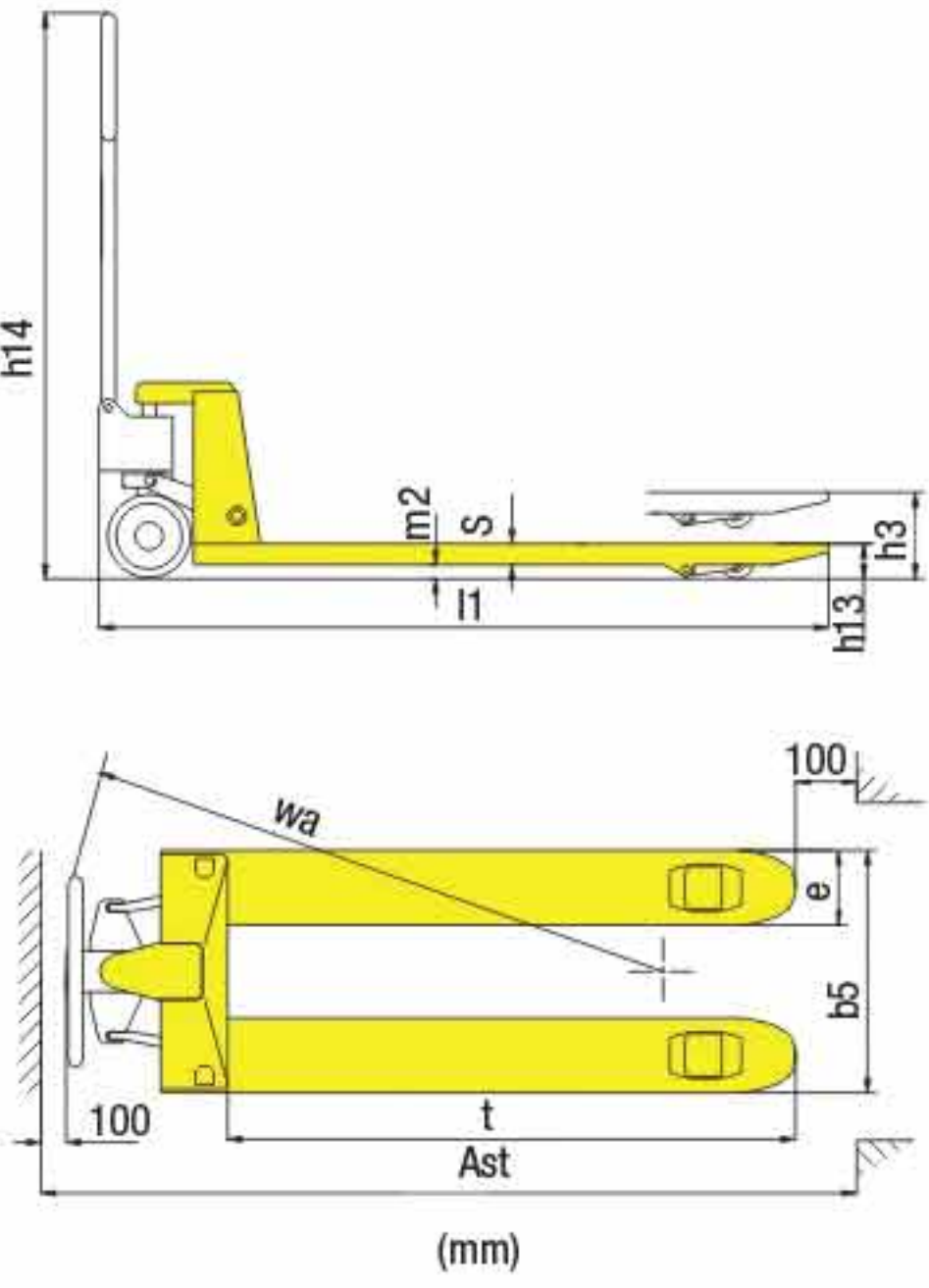

Model		TL-BF25	TL-BF35	TL-WB50
Capacity	Ton	2.5	3.5	5
Service weight	kg	70	90	105
Steering wheel	mm	ø200	ø180	ø200
Fork wheel	mm	ø80	ø75	ø84
Max. lift height	h3(mm)	185	175	195
Total height	h14(mm)	1224	1214	1240
Lowered fork height	h13(mm)	85	75	88
Overall length	l1(mm)	1533/1603	1533/1603	1533/1603
Fork dimension	s/e/t	50/160/1150	50/160/1150	60/160/1150
Distance between fork-arms outside	b5(mm)	550	550	550
Ground clearance centre of wheel base	m2(mm)	16	16	16
Aisle width for pallets 1000x1200 crossways	Ast(mm)	1730/1800	1730/1800	1730/1800
Aisle width for pallets 800x1200 lengthways	Ast(mm)	1730/1800	1730/1800	1730/1800
Turning radius	Wa(mm)	1266/1336	1266/1336	1266/1336

Standard: EN ISO 3691-5: 2014



Adjustable pump cap



Adjustable straight tappet



Option: fully rubber wrapped handle



Entry roller for easy operation

WIRE ROPE WINCH Tirfor à câble

**NEW
5.4 TON**



WIRE ROPE WINCH (ALUMINIUM BODY) [MODEL: TL-WP]

MODEL		TL-WP008	TL-WP016	TL-WP032	TL-WP054
Rated lifting capacity	Ton	0.8	1.6	3.2	5.4
Rated pulling capacity	Ton	1.2	2.4	4.8	8.1
Rated advance per full stroke	mm	52	55	28	25
Lever pull at SWL	Kg	34.77	40.78	44.66	86.67
Rope diameter	mm	8.3	11	16	20
Standard length of wire rope	m	20	20	20	20
Net weight without cable	Kg	6.7	12.3	22.2	56.5
Dimensions (mm)	A	426	545	660	930
	B	238	270	325	480
	C	64	78	100	152
	L1	-	692	692	680
	L2	-	1200	1200	1120
	L3	800	-	--	-

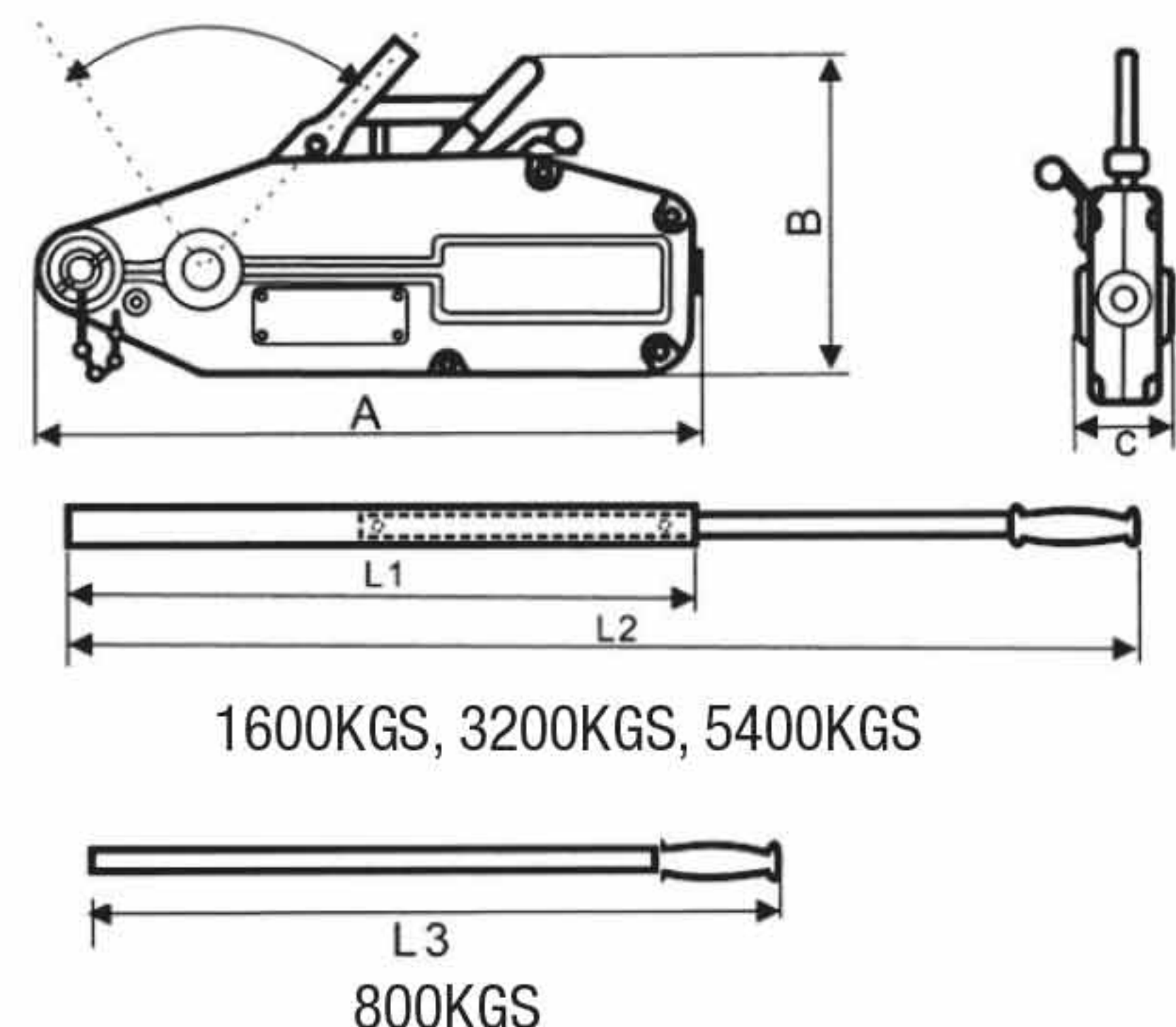

Standard: EN 13157

All dimensions are subject to change without prior notice