

HF1000:1000g 0.01g Precision Balance with Remote Display

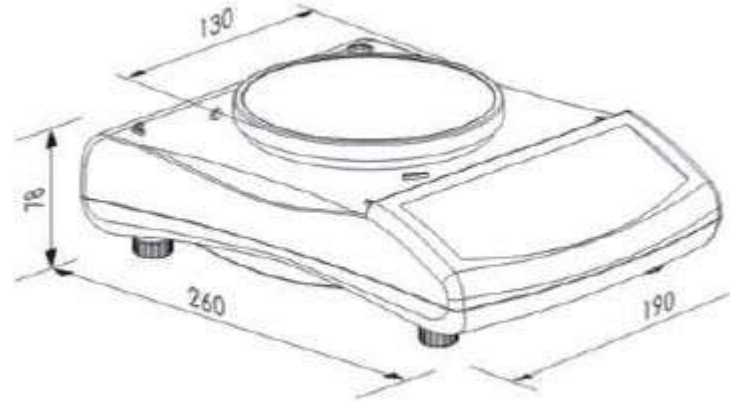

Technical Data:

Power 100-240VAC 50/60Hz – DC9V/150Ma or 6xAA batteries

Capacity 1000g

Division 0.01g~300/600/1000g

Display LCD (FSTN)

Interface RS232

Linearity Error $\pm 0.02g \sim 0.01g$

Repeatability 0.01g

Stable Time 3~5s

Units g/ct/oz/dwt/lb/dr/GN/ozt MM/tl.J/tl.T/tl.H/t/mg

S.S Pan (Dia) 130mm-0.01g

Weight 1.9kg (G.W.)/1.35kg (N.W.)

Features:

High resolution of 0.01g

Bright LCD display with backlight

Remote LCD display

RS232 Interface

Mains AC/DC adaptor

Windshield for 0.01g ones

Adjustable feet < 13 units exchange

Weighing function

Piece counting function

Percentage weighing

Auto power off selectable

Accessories

Optional printer types: Standard dot matrix printer – NT

Statistics dot matrix printer – XT110

Standard label printers – T40

Optional anti-vibration tables: 900 x 600mm – TABLE I

1200 x 600mm – TABLE II